

**DA-LITE IS MORE  
THAN PROJECTION SCREENS**

Da-Lite Tripod, Wall and  
Ceiling and Electric Screens

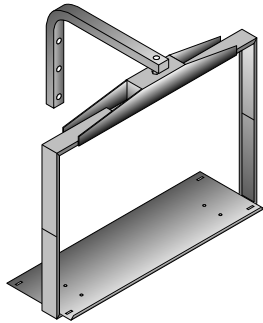

Da-Lite  
Monitor Mounts

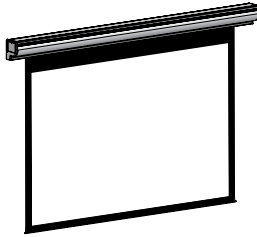
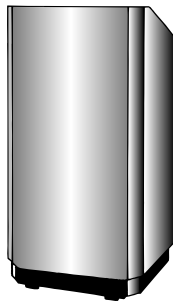

Da-Lite Lecterns



Da-Lite  
Project-O-Stands  
and Easels

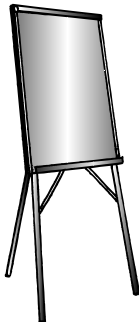

*The*  
**POWER** *In*  
**PRESENTATION PRODUCTS**

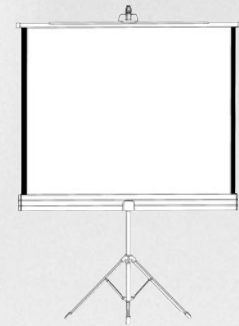

**Assembly Instructions  
for  
VERSATOL®**

**DA-LITE SCREEN COMPANY, INC.**

3100 North Detroit Street  
Post Office Box 137  
Warsaw, Indiana 46581-0137  
Phone: 574/267-8101  
800-622-3737  
Fax: 574/267-7804  
[http:// www.da-lite.com](http://www.da-lite.com)  
e-mail: [info@da-lite.com](mailto:info@da-lite.com)

YOU HAVE MADE A WISE SELECTION...

in choosing a Da-Lite projection screen, designed and engineered to produce the sharpest, most pleasing pictures with maximum convenience.

### IMPORTANT PARTS OF YOUR DA-LITE SCREEN

(When ordering parts, please specify screen model and size.)

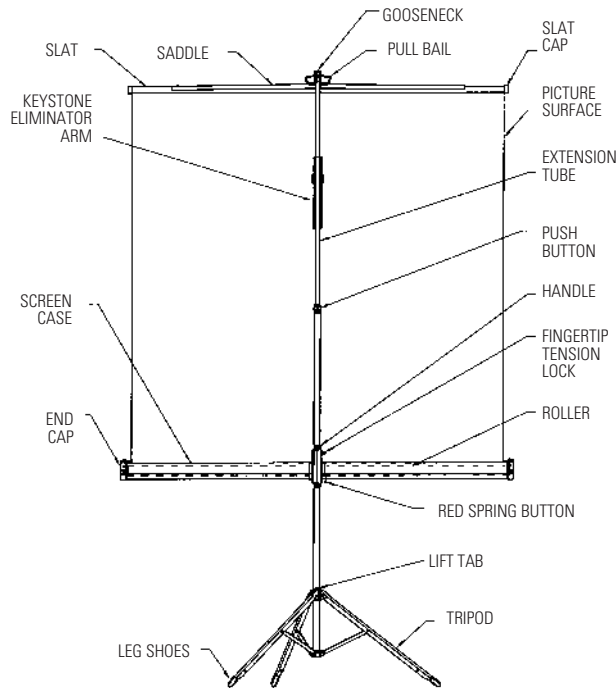

### SETTING UP YOUR SCREEN

1. Grasp screen handle with one hand. Hold in vertical position with tripod slightly above floor. Press "Push" button with other hand. Extension tube will "pop up" and tripod legs will open. Set screen on floor.
2. Swing case into horizontal position.
3. Lift picture surface by pull bail and hook over gooseneck.
4. Release fingertip tension lock and raise case.
5. Grasp bottom tube firmly with one hand. Grasp extension tube with other hand. Press "Push" button while raising extension tube—extension tube will lock in first position. Repeat until extension tube is in desired position. Finger-tip tension lock must be released to permit extension tube to be raised to highest position.
6. Press lightly down on handle until surface is taut. Lock into position by pressing down on fingertip tension lock.

### FINGERTIP TENSION LOCK

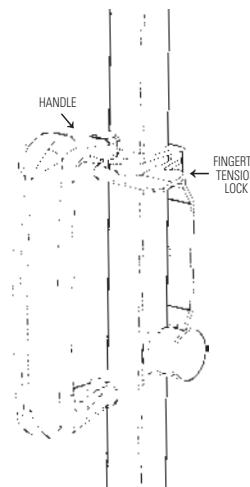

- A. Pull out the red spring button and lower case.
- B. Holding bottom tube, raise extension tube until it locks in desired position.
- C. Press lightly down on handle until surface is taut and then lock by pressing down on the fingertip tension lock.

## HOW TO USE

1. Open screen in usual manner by pressing push button.
2. Raise Eliminator to position shown below and secure by hooking ring over gooseneck.
3. Raise extension tube to first position. Lift screen surface and hook bail into one of the slots in the Eliminator. The slot used will determine the degree of tilt of the surface.
4. The screen may then be raised and lowered to the desired position by following the screen operating instructions.
5. To close, lower screen surface until bail can be easily reached.
6. Carefully lift bail from Eliminator slot and lower surface into case.
7. Lift ring from gooseneck and return Eliminator to original position. Close screen in normal manner.

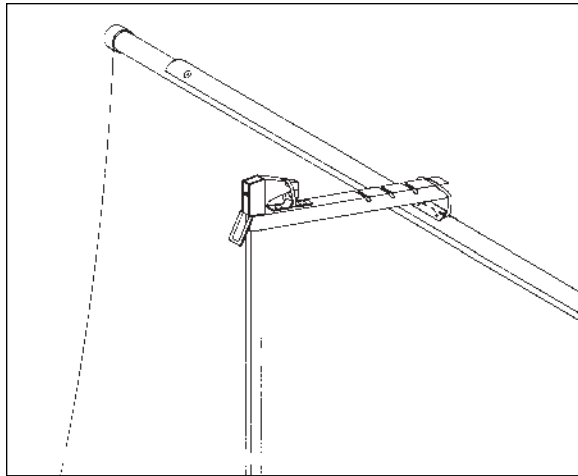

### IMPORTANT NOTE:

Use no more tilt than necessary. Use caution in tensioning screen surface when using Keystone Eliminator. Don't over-tension!

## CLOSING THE SCREEN

1. Lift fingertip tension lock to release tension.
2. Grasp extension tube with one hand. Grasp bottom tube with other hand. Lift extension tube slightly to release tension. Press "Push" button with your thumb. Lower extension tube slowly with your hand allowing surface to re-roll partially into case.
3. Lift pull bail from gooseneck and slowly complete re-rolling picture surface into case.
4. Raise or lower case until the red spring button engages into hole in bottom tube.
5. Swing case into vertical position.
6. Push gooseneck into opening on case end cap until it locks.
7. Hold bottom tube with one hand and place index finger of other hand under lift tab on leg bracket. Giving a slight lift to screen with one hand, raise lift tab quickly with other hand. Note that gooseneck and extension tube are locked for safe and comfortable carrying and storing.

## PROTECT YOUR SCREEN

Before re-rolling surface into case, examine both front and back of surface to be sure they are free of foreign matter. A Da-Lite Screen case cover is a wise and economical investment.

**QUALITY FEATURES FOR BETTER PICTURES,  
EASIER OPERATION, LONGER LIFE**

- Available with Glass Beaded or Matte White Picture Surface
- Exclusive Da-Lite Camlok® Metal Roller System prevents accidental pulling of screen surface from roller
- Automatic Push-Button Operation
- Seamless Picture Area
- Decorator Styled Cases
- Built-In Fingertip Tension Lock
- Steel Slat and Saddle on 60" x 60" and 70" x 70"
- Durable Tripod and Extension Tube
- "Gable" Constructed Tripod Legs
- No-Mar Tripod Shoes Protect Floors
- Wide Adjustable Pull Bail
- Wide Range Height Adjustment
- Tension Lever Lock for Position Adjustment

**HEAVY-DUTY CARRYING CASE**

Protect your screen's case. Screen handle protrudes for easy carrying. Sizes available for all tripod screen models.

